

Conventional Rate of Rise and Fixed Temperature Heat Detector

DC-9103E-KID



Overview

DC-9103E-KID is the new Generation of Conventional Rate of Rise and Fixed Temperature Heat from KIDDE. The DC series Detectors have a microprocessor and use Advanced Algorithms to reliably Detect Fire alarm conditions.

By Default, the DC-9103E-KID is supplied as an A1R class Heat Detector. Using the Handheld Programmer, the installer can easily program the device as an A2S or BS Detector without the need to carry 3 different heat detectors to a site..

Standard Features

- 3 classes programmable.
- Magnetic test function.
- Output terminal for remote indicator.
- Complying with AS7240.5

Connection and Wiring

The detector bottom is shown in Fig. 1 and the base in Fig. 2
There are four terminals with numbers on the base

- 1: Detection zone positive IN
- 2: Detection zone positive OUT
- 3: Detection zone negative IN and OUT
- 2: Positive Terminal of remote indicator
- 4: Negative terminal of remote indicator

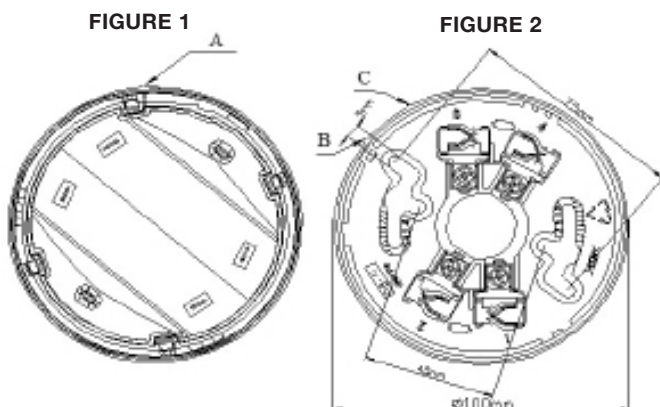

Fix the base with two tapping screws. Then align A (Fig. 1) with the bottom of the detector to B (Fig. 2) of the base, and rotate the detector clockwise to mark C.

Installation

Mounting of the detector is shown in Fig. 3

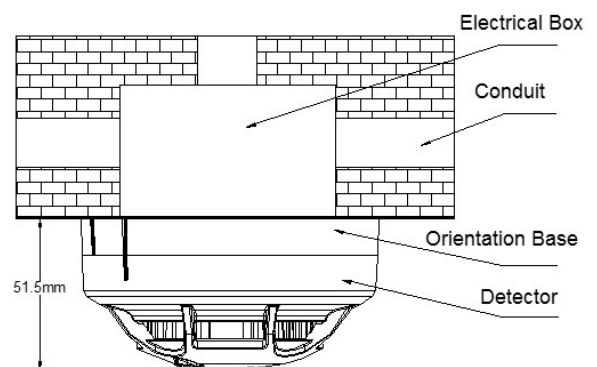

FIGURE 3

Application

Note: To operate correctly, the DC-9103E-KID must be connected to a compatible fire alarm control panel. Connecting the heat detector directly to 24VDC will damage the detector.

The default class of the detector is A1R and polling LED status is 'ON', which can be modified using P-9910B hand-held programmer.

Programming or Reading the Detector: Connect the hand-held programmer to the heat detector terminals '1' and '3' using the clips provided.

Unlocking the Programmer: Turn the programmer on and enter the unlock pin '456' and press 'clear', a '0' should appear on the LCD.

Program Heat Detector Class: To change the class, press the 'Function' key followed by '4'. A '-' should appear on the LCD. Enter: '2' for A1R, '3' for A2S, or '5' for BS, followed by the 'Program' button. Once complete, there will be a 'P' shown on the LCD, indicating its class is programmed.

Table 1 Detector Setting Parameters

| Parameter | Smoke Sensitivity | Polling LED Status |
|-----------|-------------------|--------------------|
| 2 | A1R | ON |
| 3 | A2S | ON |
| 5 | BS | ON |

Read Heat Detector Class: When the programmer is in a standby state, press the 'Test button'. 'L' will appear followed by an address for the detector. Pressing 'Up' will scroll through the detector sensitivity level, device type and heat detector class. For these Conventional Heat Detectors the detector address is not applicable. Sensitivity level is usually the same as the detector and the device type is '1', smoke detector

Locking the Programmer: press 'Clear' and enter locking pin '789' followed by 'Clear' to exit.

When the detector is connected to the KID1xxA conventional FDCIE or a addressable zone monitor unit, a 4.7kΩ end of line resistor is to be fitted at the last DB-01 base on the circuit. See Fig. 4.

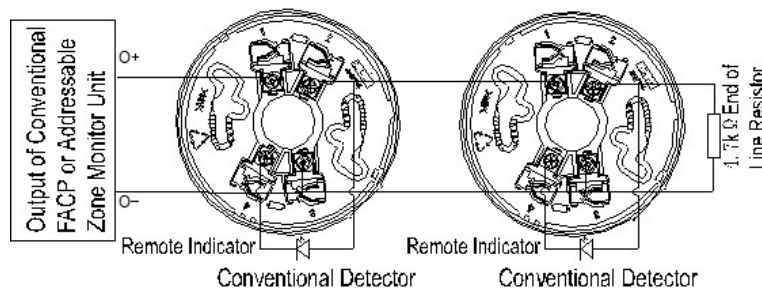

FIGURE 4

Testing

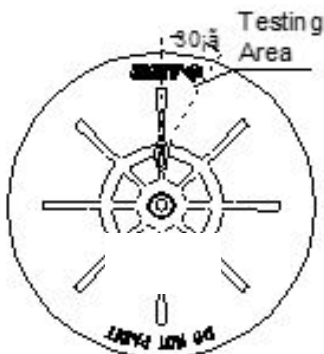

FIGURE 5

Note: Before testing, Ensure the detector is properly installed and powered up. Testing can only commence after the detector is powered up for a minimum 10 seconds.

The detector must be tested after installation and regular maintenance as per local code. The two methods are as follows:

- (1) Reed switch testing
Place the commission tool on the testing area of the detector as shown in Fig. 5, hold for several seconds until the detector is in alarm.
- (2) Smoke test
Apply the detector smoke tester to the detector until it alarms.

On completion of test, reset the detector at the FDCIE.

If a detector fails during testing, follow the instructions outlined in the Maintenance section, and retest it. If it still fails, replace the detector.



Australia & New Zealand

Phone: 1800 672 171
Outside Australia: +61 3 9518 5588
Email: cs@firesecurityproducts.zendesk.com
Web: www.kidde.com.au

Head Office

10 Ferntree Place
Notting Hill, Victoria 3168
Australia

© 2021 Carrier. All rights reserved.
Kidde Australia is a Carrier company.

Maintenance

Before performing maintenance ensure the proper authorities are notified that the system is undergoing maintenance and will temporarily be out of service. Disable the zone or system undergoing maintenance to avoid any unwanted alarms.

Prior to commissioning ensure the dust covers are left on the detectors and measures are taken to keep the detectors free from dust, dampness and corrosion.

Detectors should be cleaned at least once a year to ensure normal operation of the system.

The detector should be tested after any cleaning or when replaced

Protect the metal component on the PCB against damp and improper distortion.

Specifications

| | |
|--|--|
| Operating Voltage | 24VDC(16VDC~28VDC) |
| Standby Current | ≤60μA |
| Alarm Current | ≤55mA |
| Fire LED | Red, periodically flash once in polling when the status is set to "ON"; no illumination when the status is set to "OFF". Periodically flash twice in fault; steady illumination when in alarm. |
| Remote Indication Output | Polarity-sensitive, directly connecting with remote indicator (built in 10k resistor in series, maximum output current is 2.0mA); |
| The remote indicator does not illuminate in normal and flashes in alarm. | 2V (peak to peak value) |
| Class and Setup | Classes A1R, A2S, BS programmable. |
| Maximum Ripple Voltage | 2V (peak-to-peak) |
| Alarm Reset | Instantaneous cut-out (10s Min, 1.0VDCMax.) |
| Wiring | Polarized two wire |
| Ingress Protection Rating | IP2X |
| Ambient Temperature | Class A1: -10°C~+50°C Class A2: -10°C~+50°C Class B: -10°C~+65°C |
| Typical Fixed Temperature | Class A1: 58°C Class A2: 62°C Class B: 77°C |
| Relative Humidity | ≤95%, non-condensing |
| Material | ABS |
| Dimensions | Diameter: 100mm Height: 53.3mm (with base) |
| Mounting Hole Spacing | 45mm~75mm |
| Weight | About 110g (with base) |

Accessories and Tools

| Module | Name | Remarks |
|---------|---------------------|------------------|
| P-9910B | Handheld Programmer | Order separately |
| DB-01 | Base | Order separately |

Ordering information

| Part number | Description | Ship Wt., lb (kg) |
|--------------|---|-------------------|
| DC-9103E-KID | Conventional Rate of Rise and Fixed Temperature Heat Detector | |