

# Intelligent 4D Multisensor Detector

## SIGA-IPHSI



7272-1657:  
0126



## Overview

People detect danger by relating many observations to one another and comparing them to familiar patterns. The simultaneous use of multiple senses allow humans to filter out situations which are not dangerous. The ability to detect danger depends largely on intelligence and knowledge from past experience. EST 4D detectors provide both.

The SIGA-IPHSI Intelligent 4D Multisensor Detector gathers analogue information from each of its three fire sensing elements (ionization, photoelectric, and heat) and converts it into digital signals. The detector's on-board microprocessor measures and analyzes these signals separately with respect to a fourth element - Time. We call this technology 4D. It compares the information to historical readings, time patterns and several known fire characteristics to make an alarm decision. Digital filters remove signal patterns that are not typical of fires. Unwanted alarms are virtually eliminated.

## Standard Features

### Integrates three sensing technologies

Processes and analyzes information from each sensor (ion/photo/heat) separately using dynamic filters then applies a sophisticated algorithm for optimum detection accuracy.

### Non-volatile memory

Permanently stores serial number, type of device, and job number. Automatically updates historic information including hours of operation, last maintenance date, number of alarms and troubles, time of last alarm1 and analogue signal patterns for each sensing element just before last alarm.

### Automatic device mapping

Each detector transmits wiring information regarding its location with respect to other devices on the circuit. Detectors installed in the wrong location during cleaning are automatically reported to the loop controller.

### Electronic addressing

Permanently stores programmable address; there are no switches or dials to set. Addresses are downloaded from a PC, or the SIGA-PRO Signature Program/Service Tool.

### Environmental compensation

Each sensing element self-compensates for changes in the detector's installed environment to maintain the sensitivity setting and prevent unwanted alarms. The detector reports when it cannot compensate any further.

### Integral microprocessor — Intelligent detector

All decisions are made at the detector allowing lower communication speed while substantially improving control panel response time. Less sensitive to line noise and loop wiring properties; twisted or shielded wire is not required.

### Wide 0.67 — 3.70%/ft. sensitivity range window

Program the detector to operate at any one of five sensitivity settings within the window.

### Pre-alarm

Detector stores one of 20 pre-alarm sensitivity values to alert local personnel prior to the sensor reaching a full evacuation sensitivity. Sensitivity values can be set in 5% increments.

*Note: Some features described here may not be supported by all control systems. Check your control panel's Installation and Operation Guide for details.*

### Identification of dirty or defective detector

Self-diagnostic and sensitivity check provides a dirty detector signal.

### Automatic day/night sensitivity adjustment

Makes detector more sensitive during inactive nighttime periods.

### Stable design

Sensitivity remains stable with air velocity up to 500 ft/min (2.53m/sec) making it suitable for direct insertion in low velocity duct applications.

### Designed for high ambient temperature operation

Install in ambient temperatures up to 100° F (38° C).

### Twin status LEDs

Flashing GREEN shows normal; flashing RED shows alarm state. LEDs are visible from any direction.

### Standard, relay, fault isolator, and audible mounting bases

Four mounting bases provide clamp terminals, allow room side wiring and include an optional tamper-resist feature.

### Designed to ISO 9001 standards

Manufactured to strict international quality standards for highest reliability.

## Signature Series Overview

The microprocessor in each detector provides four additional benefits - Self-diagnostics and History Log, Automatic Device Mapping, and Fast, Stable Communication.

**Self-diagnostics and History Log** - Each Signature Series detector constantly runs self-checks to provide important maintenance information. The results of the self-check are automatically updated and permanently stored in the detector's non-volatile memory. This information is accessible for review any time at the control panel, PC, or by using the SIGA-PRO Signature Program/Service Tool.

**Automatic Device Mapping** - The loop controller learns where each device's serial number address is installed relative to other devices on the circuit. This mapping feature provides supervision of each device's installed location to prevent a detector from being reinstalled (after cleaning etc.) in a different location from where it was originally. The history log for the detector remains relevant and intact regardless of its new location.

The Signature Series Data Entry Program also uses the mapping feature. With interactive menus and graphic support, the wired circuits between each device can be examined. Layout or "as-built" drawing information showing wire branches (T-taps), device types and their address are stored on disk for printing hard copy. This takes the mystery out of the installation. The preparation of as-built drawings is fast and efficient.

**Fast Stable Communication** - On-board intelligence means less information needs to be sent between the detector and the loop controller. Other than regular supervisory polling response, the detector only needs to communicate with the loop controller when it has something new to report. This provides very fast control panel response time and allows a lower baud rate (speed) to be used for communication on the circuit.

**Environmental Compensation** - Detection sensitivity for the SIGA-IPHS is virtually independent of its installed environment and its physical condition. Environmental compensation means each sensing element adapts to long-term changes caused by dirt, humidity, temperature, aging etc. It even compensates for small amounts of normal ambient smoke. Approximately six times every hour, the detector adjusts and updates the sensitivity (% obscuration) and ambient temperature baselines for each sensing element. Signature Series environmental compensation is so reliable that it meets NFPA72 field sensitivity testing requirements — without the need for external meters.

**Sensitivity Range** - The SIGA-IPHS has a sensitivity range or window of 2.2% - 12.4% obscuration per meter. The installer selects the detector's ALARM sensitivity level. Five settings ranging from the least sensitive at 3.5% obscuration/ft to the most sensitive at 1.0% obscuration/ft are available.

**Pre-Alarm** - Pre-alarm warnings may alert local staff to a possible fire condition allowing them to investigate before entering into a full alarm condition which requires building evacuation. The 4D multisensor's wide sensitivity range permits the use of early warning pre-alarm values. The pre-alarm value can be set by the user in 5% increments, allowing up to 20 pre-alarm settings.

**Automatic Day/Night Sensitivity Selection** - Signature Series detectors may be programmed for different sensitivities during day and night periods. This allows the detector to be more sensitive during unoccupied periods when lower ambient background conditions are expected.

**Stability** - The 4D detector's sensitivity remains stable in wind velocities up to 500 ft/min (2.53 m/sec). Ambient temperature has very little affect on the detector. The detector may be installed in rooms with ambient temperatures up to 100°F (38°C).

**Status LEDs** - Twin LEDs are visible from any direction. A flashing GREEN LED shows normal system polling from the loop controller. A flashing RED LED means the detector is in alarm state. Normal GREEN LED activity is not distracting to building occupants, but can be quickly spotted by a maintenance technician.

**Electronic Addressing** - The loop controller electronically addresses each detector, saving valuable time during system commissioning. Setting complicated switches or dials is not required. Each detector has its own unique serial number stored in its on-board memory. The loop controller identifies each device on the circuit and assigns a "short" address to that device's serial number. If desired, detectors can be addressed using the SIGA-PRO Signature Program/Service Tool.

## Application

With intelligent 4D multisensor detectors, unwanted alarms go down to nearly zero and the detection of all types of fire increases to nearly 100%. The European standard DIN EN 54 part 9 describes six standard test fires used to rate the sensitivity of heat, ionization, and photoelectric smoke detectors. No single sensing element is equally suitable for all test fires.

The table below shows that the 4D detector is suited for all applications. Normal detector spacing guidelines should be followed.

SIGA-IPHS detectors are compatible only with EST's Signature Loop Controller.

Test Fire	SIGA-PSI Photo	SIGA-HRAA and SIGA-HFAB Rate-of-Rise/Fixed Temp.	SIGA-PHSI Photo Heat 3D	SIGA-IPHS Ion/Photo/Heat 4D
Open Wood	unsuitable	optimum	very suitable	optimum
Wood Pyrolysis	optimum	unsuitable	optimum	optimum
Smouldering Cotton	optimum	unsuitable	optimum	optimum
Poly Urethane Foam	very suitable	suitable	very suitable	optimum
n-Heptane	very suitable	very suitable	optimum	optimum
Liquid Fire without Smoke	unsuitable	optimum	very suitable	very suitable

Depending on the type of fire expected in a protected space, the designer usually chooses from three types of sensor technology. Ionization sensors respond well to fast, flaming fires. Photoelectric sensors respond well to smoldering fires, and heat sensors are used as backup or in environmentally poor atmospheres for smoke detection. Agency requirements demand that ionization sensors respond to smoldering fires and that photoelectric sensors respond to flaming fires. This makes single element sensors more prone to false alarms and slow to respond to fires that are difficult for them to detect.

Only when ALL three fire sensing elements — Ionization, Photoelectric and Heat — are suitably combined into one detector can ALL types of fires be effectively detected while virtually eliminating false alarms.

When 4D multisensor detectors are installed, a fire alarm system does not have to be altered when the application or the type of "expected" fire changes. The guesswork is removed. The SIGA-IPHSI 4D detector is suited for all fire detection applications.

## Installation

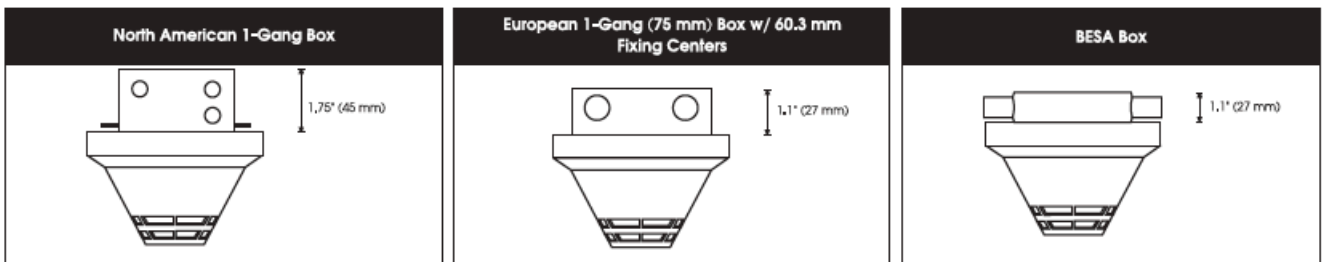
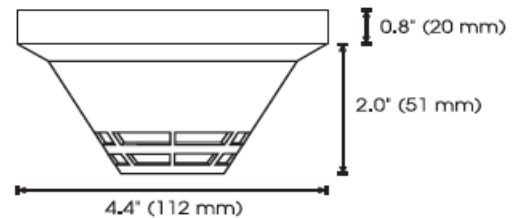
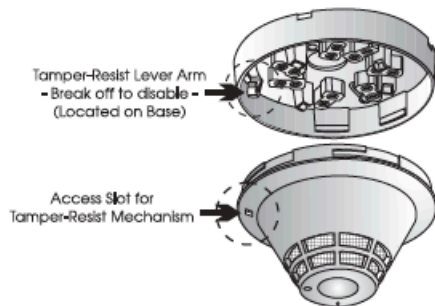

# Typical Wiring

The detector mounting bases accept #18 AWG (0.75mm<sup>2</sup>), #16 AWG (1.0mm<sup>2</sup>), #14 AWG (1.5mm<sup>2</sup>), and #12 AWG (2.5mm<sup>2</sup>) wire sizes.

Note: Sizes #16 AWG (1.0mm<sup>2</sup>) and #18 AWG (0.75mm<sup>2</sup>) are preferred for ease of installation. See Signature Loop Controller catalogue sheet for detailed wiring requirement specifications.

## Standard Detector Base, SIGA-SB, SIGA-SB4

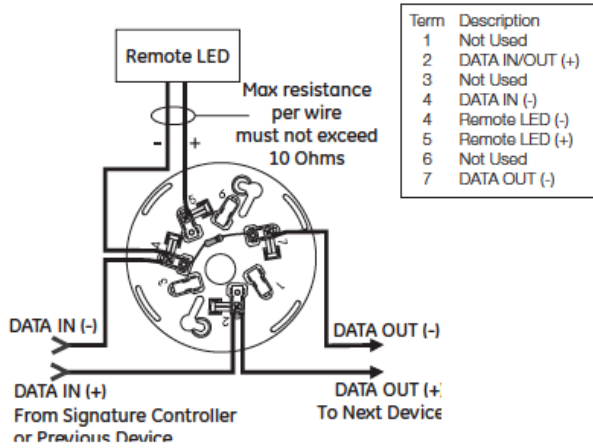

## Relay Detector Base, SIGA-RB, SIGA-RB4

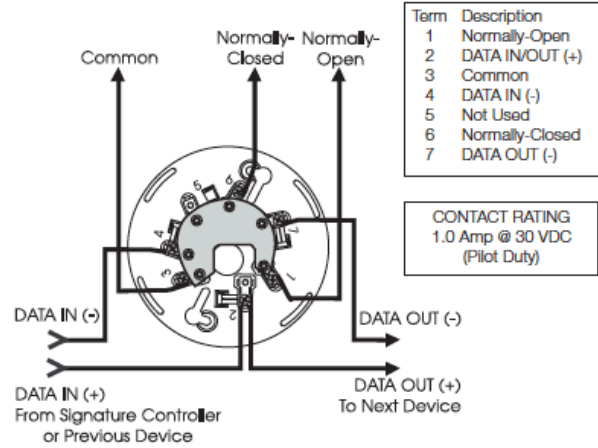

## Isolator Detector Base, SIGA-IB, SIGA-IB4

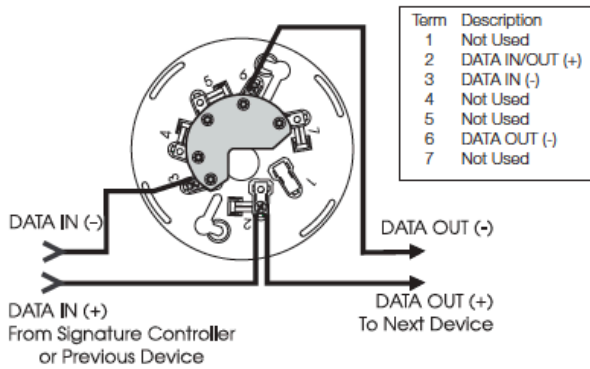

## Audible Detector Base, SIGA-AB4G

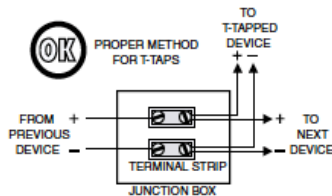
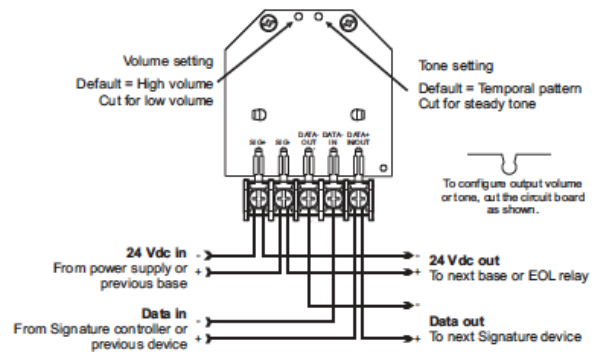

## Warnings and Cautions

This detector will not operate without electrical power. As fires frequently cause power interruption, we suggest you discuss further safeguards with your fire protection specialist.

This detector will NOT sense fires that start in areas where smoke or heat cannot reach the detector. Smoke or heat from fires in walls, roofs, or on the opposite side of closed doors may not reach the detector to alarm it.

The heat sensor in this device only provides a source of information to supplement the information provided by the ionization and photoelectric smoke sensors. The heat sensor by itself does NOT protect life against fire and smoke.

## Accessories

All detector mounting bases have wiring terminals that are accessible from the "room-side" after mounting the base to the electrical box. The bases mount to North American 1-gang boxes and to 3½ inch or 4 inch octagon boxes, 1½ inches (38 mm) deep. They also mount to European BESA and 1-gang boxes with 60.3 mm fixing centers. The SIGA-SB4, SIGA-RB4, and SIGA-IB4 mount to North American 4 inch sq. electrical boxes in addition to the above boxes. They include the SIGA-TS4 Trim Skirt which is used to cover the "mounting ears" on the base. The SIGA-AB4G mounts to a 4" square box only.



**Standard Base SIGA-SB, SIGA-SB4** - This is the basic mounting base for EST Signature Series detectors. The SIGA-LED-AU Remote LED is supported by the Standard Base.

**Relay Base SIGA-RB, SIGA-RB4** - This base includes a relay. Normally open or closed operation is selected during installation. The dry contact is rated for 1 amp (pilot duty) @ 30 Vdc. The relay's position is supervised to avoid accidentally jarring it out of position. The SIGA-RB can be operated as a control relay if programmed to do so at the control panel (EST3 V. 2 only). The relay base does not support the SIGA-LED-AU Remote LED.

**Audible Base SIGA-AB4G** - This base is designed for use where localized or group alarm signaling is required. When the detector senses an alarm condition, the audible base emits a local alarm signal. The optional SIGA-CRR Polarity Reversal Relay can be used for sounding to other audible bases on the same 24 Vdc circuit.

Relay and Audible Bases operate as follows:

- at system power-up or reset, the relay is de-energized.
- when a detector is installed in the base with the power on, the relay energizes for four seconds, then de-energizes.
- when a detector is removed from a base with the power on, the relay is de-energized.
- when the detector enters the alarm state, the relay is energized.

## Testing & Maintenance

Each detector automatically identifies when it is dirty or defective and causes a "dirty detector" message. The detector's sensitivity measurement can also be transmitted to the loop controller. A sensitivity report can be printed to satisfy NFPA sensitivity measurements which must be conducted at the end of the first year and every two years thereafter.

The user friendly maintenance program shows the current state of each detector and other pertinent messages. Single detectors may be turned off temporarily, from the control panel. Availability of maintenance features is dependent on the fire alarm system used.

Scheduled maintenance (Regular or Selected) for proper detector operation should be planned to meet the requirements of the Authority Having Jurisdiction (AHJ). Refer to current NFPA 72 and ULC CAN/ULC 536 standards.

**Isolator Base SIGA-IB, SIGA-IB4** - This base includes a built-in line fault isolator for use on Class A circuits. A detector must be installed for it to operate. The isolator base does not support the SIGA-LED-AU Remote LED.

The isolator operates as follows:

- a short on the line causes all isolators to open within 23 msec
- at 10 msec intervals, beginning on one side of the Class A circuit nearest the loop controller, the isolators close to provide the next isolator down the line with power
- when the isolator next to the short closes, it reopens within 10 msec.

The process repeats beginning on the other side of the loop controller.

**Remote LED SIGA-LED-AU** - The remote LED connects to the SIGA-SB or SIGA-SB4 Standard Base only. It features a North American size 1-gang plastic faceplate with a white finish and red alarm LED.

**SIGA-TS4 Trim Skirt** - Supplied with 4 inch bases, it can also be ordered separately to use with the other bases to help hide surface imperfections not covered by the smaller bases. Use black model (SIGA-TSB) with SIGA-IPHSB.





**Australia & New Zealand**

Phone: 1800 672 171  
 Outside Australia: +61 3 9518 5588  
 Email: firesecuritycs@fs.utc.com  
 Web: www.kidde.com.au

**Head Office**

10 Ferntree Place  
 Notting Hill, Victoria 3168  
 Australia

© 2017 Kidde Australia Pty Ltd. Kidde Australia is a UTC Climate, Controls & Security company, a unit of United Technologies Corporation.

REF: E85001-0245-AU 4D Intelligent Detector

## Specifications

Agency Listings	ActivFire, UL, ULC, CSFM, MEA, FM
Ion Sensor	(unipolar) 0.135µC Americium 241
Photo Sensor	Light Scattering Principle
Heat Sensor	Alarms at 65°F (35°C) above ambient
Storage and Operating Environment	Air Velocity Range: 0 to 500 ft/min (0 to 2.53 m/s) Operating Temperature: 0°C to 38°C Storage Temperature: -20°C to 60°C Humidity: 0 to 93% RH, Non-condensing Altitude: 1828m above sea level maximum
Sensitivity Range	ULI/ULC - 0.67% to 3.70% obscuration/foot
User Selected Alarm Sensitivity Settings	Most Sensitive: 1.0%/ft. More Sensitive: 2.0%/ft. Normal: 2.5%/ft. Less Sensitive: 3.0%/ft Least Sensitive: 3.5%/ft.
Pre-alarm Sensitivity	5% increments, allowing up to 20 pre-alarm settings
Operating Voltage	15.2 to 19.95 Vdc (19 Vdc nominal)
Operating Current	Quiescent: 45µA @ 19 V. Alarm: 45µA @ 19 V. Pulse Current: 100µA (100 msec).
Construction & Finish	High-Impact Engineering Polymer - White or Black
Compatible Mounting Bases	SIGA-SB Standard Base, SIGA-RB Relay Base, SIGA-IB Isolator Base, SIGA-AB4, AB4G Audible Bases
LED Operation	On-board Green LED - Flashes when polled. On-board Red LED - Flashes when in alarm. Remote Red LED (model SIGA-LED-AU) Flashes when in alarm.
Compatibility	Use With Signature Loop Controller
Address Requirements	Uses one Device Address
UL Listed Spacing	30 ft.

## Ordering Information

Catalogue Number	Description	Ship Wt. lbs (kg)
SIGA-IPHSI	Intelligent 4D Multisensor Detector - EN54/ActivFire Listed	.5 (.23)
SIGA-IPHSB	Intelligent 4D Multisensor Detector (Black) - ActivFire/UL/ULC Listed	.5 (.23)
<b>Accessories</b>		
SIGA-SB	Detector Mounting Base - Standard	
SIGA-SB4	4-inch Detector Mounting Base c/w SIGA-TS4 Trim Skirt	
SIGA-RB	Detector Mounting Base w/Relay	
SIGA-RB4	4-inch Detector Mounting Base w/Relay, c/w SIGA-TS4 Trim Skirt	
SIGA-IB	Detector Mounting Base w/Fault Isolator	0.2 (.09)
SIGA-IB4	4-inch Detector Mounting Base w/ Fault Isolator, c/w SIGA-TS4 Trim Skirt	
SIGA-LED-AU	Remote Alarm LED with indicator labels	
SIGA-AB4G	Audible (Sounder) Base	.3 (0.15)
SIGA-TS4	Trim Skirt (supplied with 4-inch bases)	.1 (.04)
SIGA-TSB	Trim Skirt - Black (use with black detector)	.1 (.04)
SIGA-TS	Trim Skirt - (optional for non-4" bases)	.1 (.04)