

Intelligent 3D Multisensor Detector

SIGA-PHSI

 7272-1657:
0126

Overview

The Signature Series Model SIGA-PHSI Intelligent 3D Multisensor Detector gathers analog information from each of its two fire sensing elements (photoelectric and heat) and converts it into digital signals. The detector's on-board microprocessor measures and analyzes these signals separately with respect to a third element - Time. We call this technology 3D. It compares the information to historical readings, time patterns, and several known fire characteristics to make an alarm decision. Digital filters remove signal patterns that are not typical of fires. Unwanted alarms are virtually eliminated.

Standard Features

- Integrates photoelectric smoke and 135 ° F (57 ° C) fixed-temperature heat sensing technologies
- Non-volatile memory
- Automatic device mapping
- Electronic addressing
- Environmental compensation
- Integral microprocessor - intelligent detector
- Wide 0.67% to 3.77%/ft. sensitivity range
- Twenty pre-alarm sensitivity values, set in 5% increments
- Identification of dirty or defective detectors
- Automatic day/night sensitivity adjustment
- Twin RED/GREEN status LEDs
- Standard, relay, fault isolator, and audible mounting bases
- Designed and manufactured to ISO 9001 standards

Note: Some features described here may not be supported by all control systems. Check your control panel's Installation and Operation Guide for details.

Signature Series Overview

The microprocessor in each detector provides four additional benefits - Self-diagnostics and History Log, Automatic Device Mapping, and Fast, Stable Communication.

Self-diagnostics and History Log - Each Signature Series detector constantly runs self-checks to provide important maintenance information. The results of the self-check are automatically updated and permanently stored in the detector's non-volatile memory. This information is accessible for review any time at the control panel, PC, or by using the SIGA-PRO Signature Program/Service Tool.

Automatic Device Mapping - The loop controller learns where each device's serial number address is installed relative to other devices on the circuit. This mapping feature provides supervision of each device's installed location to prevent a detector from being reinstalled (after cleaning etc.) in a different location from where it was originally. The history log for the detector remains relevant and intact regardless of its new location.

The Signature Series Data Entry Program also uses the mapping feature. With interactive menus and graphic support, the wired circuits between each device can be examined. Layout or "as-built" drawing information showing wire branches (T-taps), device types and their address are stored on disk for printing hard copy. This takes the mystery out of the installation. The preparation of as-built drawings is fast and efficient.

Fast Stable Communication - On-board intelligence means less information needs to be sent between the detector and the loop controller. Other than regular supervisory polling response, the detector only needs to communicate with the loop controller when it has something new to report. This provides very fast control panel response time and allows a lower baud rate (speed) to be used for communication on the circuit.

Environmental Compensation - Detection sensitivity for the SIGA-PHSI is virtually independent of its installed environment and its physical condition. Environmental compensation means each sensing element adapts to long-term changes caused by dirt, humidity, temperature, aging etc. It even compensates for small amounts of normal ambient smoke.

Sensitivity Range - The SIGA-PHSI has a sensitivity range or window of 0.67 - 3.70% obscuration per foot. The installer selects the detector's ALARM sensitivity level. Five settings ranging from the least sensitive at 3.5% obscuration/ft to the most sensitive at 1.0% obscuration/ft are available.

Automatic Day/Night Sensitivity Selection - Signature Series detectors may be programmed for different sensitivities during day and night periods. This allows the detector to be more sensitive during unoccupied periods when lower ambient background conditions are expected.

Stability - The 3D detector's sensitivity remains stable in wind velocities up to 500 ft/min (2.53 m/sec). Ambient temperature has very little affect on the detector. The detector may be installed in rooms with ambient temperatures up to 100°F (38°C).

Electronic Addressing - The loop controller electronically addresses each detector, saving valuable time during system commissioning. Setting complicated switches or dials is not required. Each detector has its own unique serial number stored in its on-board memory. The loop controller identifies each device on the circuit and assigns a "soft" address to that device's serial number. If desired, detectors can be addressed using the SIGA-PRO Signature Program/Service Tool.

Compatibility

The SIGA-PHSI detectors are compatible only with the Signature Loop Controller.

Application

Although photoelectric detectors have a wide range of fire sensing capabilities they are best suited for detecting slow, smoldering fires. The table below shows six standard test fires used to rate the sensitivity of smoke and heat detectors. The table indicates that no single sensing element is suited for all test fires. EST recommends that this detector be installed according to latest recognised edition of national and local fire alarm codes.

Test Fire	SIGA-PSI Photo	SIGA-HRAA and SIGA-HFAB Rate-of-Rise/ Fixed Temp.	SIGA-PHSI Photo Heat 3D	SIGA-IPHSI Ion/Photo/Heat 4D
Open Wood	unsuitable	optimum	very suitable	optimum
Wood Pyrolysis	optimum	unsuitable	optimum	optimum
Smouldering Cotton	optimum	unsuitable	optimum	optimum
Poly Urethane Foam	very suitable	suitable	very suitable	optimum
n-Heptane	very suitable	very suitable	optimum	optimum
Liquid Fire without Smoke	unsuitable	optimum	very suitable	very suitable

Testing & Maintenance

Each detector automatically identifies when it is dirty or defective and causes a "dirty detector" message. The detector's sensitivity measurement can also be transmitted to the loop controller. A sensitivity report can be printed to satisfy NFPA sensitivity measurements which must be conducted at the end of the first year and every two years thereafter.

The user-friendly maintenance program shows the current state of each detector and other pertinent messages. Single detectors may be turned off temporarily, from the control panel. Availability of maintenance features is dependent on the fire alarm system used. Scheduled maintenance (Regular or Selected) for proper detector operation should be planned to meet the requirements of the Authority Having Jurisdiction (AHJ).

Installation

Signature Series detectors mount to North American 1-gang boxes, 3-1/2 inch or 4 inch octagon boxes, and to 4 inch square electrical boxes 1-1/2 inches (38 mm) deep. They mount to European BESA and 1-gang boxes with 60.3 mm fixing centers.

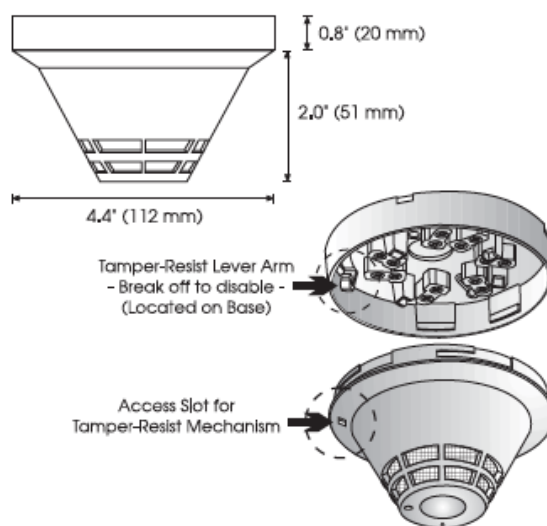

Typical Wiring

The detector mounting bases accept #18 AWG (0.75mm²), #16 (1.0mm²), #14 AWG (1.5mm²), and #12 AWG (2.5mm²) wire sizes. Note: Sizes #16 AWG (1.0mm²) and #18 AWG (0.75mm²) are preferred for ease of installation. See Signature Loop Controller catalog sheet for detailed wiring requirement specifications.

Standard Detector Base, SIGA-SB, SIGA-SB4

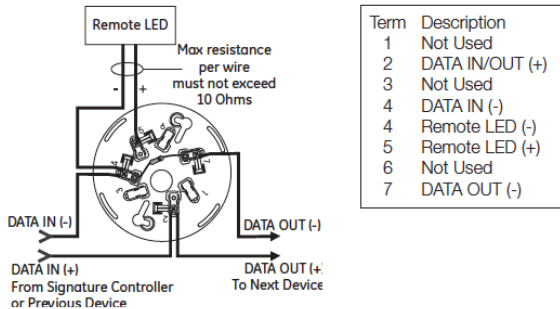

Relay Detector Base, SIGA-RB, SIGA-RB4

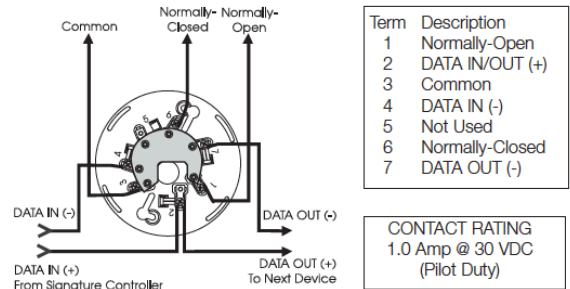

Isolator Detector Base, SIGA-IB, SIGA-IB4

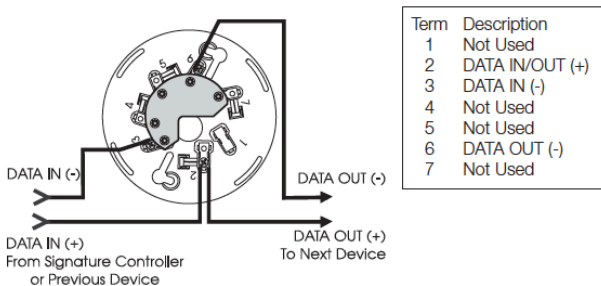

Audible Detector Base, SIGA-AB4G

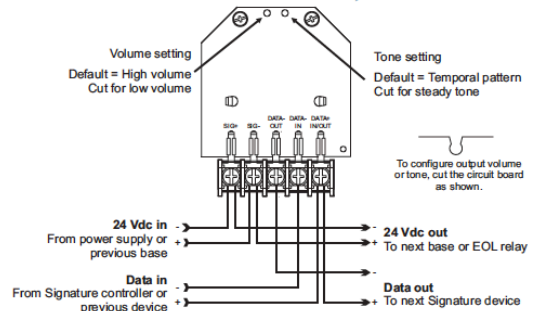

Accessories

All detector mounting bases have wiring terminals that are accessible from the "room-side" after mounting the base to the electrical box. The bases mount to North American 1-gang boxes and to 3½ inch or 4 inch octagon boxes, 1½ inches (38 mm) deep. They also mount to European BESA and 1-gang boxes with 60.3 mm fixing centers. The SIGA-SB4, SIGA-RB4, and SIGA-IB4 mount to North American 4 inch square electrical boxes in addition to the above boxes. They include the SIGA-TS4 Trim Skirt which is used to cover the "mounting ears" on the base. The SIGA-AB4G mounts to a 4" square box only.

Standard Base SIGA-SB, SIGA-SB4 - This is the basic mounting base for EST Signature Series detectors. The SIGA-LED Remote LED is supported by the Standard Base.

Relay Base SIGA-RB, SIGA-RB4 - This base includes a relay.



Normally open or closed operation is selected during installation. The dry contact is rated for one amp (pilot duty) @ 30 Vdc. The relay's position is supervised to avoid accidentally jarring it out of position. The SIGA-RB can be operated as a control relay if programmed to do so at the control panel (EST3 V. 2 only). The relay base does not support the SIGA-LED Remote LED.

Audible Base SIGA-AB4G - This base is designed for use where localized or group alarm signaling is required. When the detector senses an alarm condition, the audible base emits a local alarm signal. The optional SIGA-CRR Polarity Reversal Relay can be used for sounding to other audible bases on the same 24 Vdc circuit.

Relay and Audible Bases operate as follows:

- at system power-up or reset, the relay is de-energized
- when a detector is installed in the base with the power on, the relay energizes for four seconds, then de-energizes
- when a detector is removed from a base with the power on, the relay is de-energized
- when the detector enters the alarm state, the relay is energized.

Isolator Base SIGA-IB, SIGA-IB4 - This base includes a built-in line fault isolator for use on Class A circuits. A detector must be installed for it to operate. The isolator base does not support the SIGA-LED-AU Remote LED.

The isolator operates as follows:

- a short on the line causes all isolators to open within 23 msec.
- at 10 msec intervals, beginning on one side of the Class A circuit nearest the loop controller, the isolators close to provide the next isolator down the line with power.
- when the isolator next to the short closes, it reopens within 10 msec.

The process repeats beginning on the other side of the loop controller.

Remote LED SIGA-LED - The remote LED connects to the SIGA-SB or SIGA-SB4 Standard Base only. It features a North American size 1-gang plastic faceplate with a white finish and red alarm LED.

SIGA-TS4 Trim Skirt - Supplied with 4 inch bases, it can also be ordered separately to use with the other bases to help hide surface imperfections not covered by the smaller bases.



Australia & New Zealand

Phone: 1800 672 171
 Outside Australia: +61 3 9518 5588
 Email: cs@firesecurityproducts.zendesk.com
 Web: www.kidde.com.au

Head Office

10 Ferntree Place
 Notting Hill, Victoria 3168
 Australia

© 2022 Carrier. All rights reserved.
 Kidde Australia is a Carrier company.

Warnings & Cautions

This detector will not operate without electrical power. As fires frequently cause power interruption, we suggest you discuss further safeguards with your fire protection specialist. This detector will NOT sense fires that start in areas where smoke or heat cannot reach the detector. Smoke from fires in walls, roofs, or on the opposite side of closed doors may not reach the detector to alarm it. The heat sensor in this device only provides a source of information to supplement the information provided by the photoelectric smoke sensor. The heat sensor by itself does NOT protect life against fire and smoke.

Specifications

Smoke Sensing Element	Photoelectric - Light Scattering Principle
Heat Sensing Element	Fixed Temperature Alarms at 135°F (57°C) Ambient
Operating and Storage Environment	Operating Temp: 32°F to 100°F (0°C to 38°C) Storage Temp: -4°F to 140°F (-20°C to 60°C) Humidity: 0 to 93% RH, Non-Condensing
Sensitivity Range	ULI/ULC - 0.67% to 3.77%
User Selected Alarm Sensitivity Settings	Most Sensitive: 1.0%/ft. More Sensitive: 2.0%/ft. Normal: 2.5%/ft. Less Sensitive: 3.0%/ft. Least Sensitive: 3.5%/ft.
Pre-alarm Sensitivity	5% increments, allowing up to 20 pre-alarm settings
Operating Voltage	15.2 to 19.95 Vdc (19 Vdc nominal)
Operating Current	Quiescent: 45µA @ 19 V. Alarm: 45µA @ 19 V. Pulse Current: 100 µA (100 msec). During Communication: 9 mA maximum.
Construction & Finish	High Impact Engineering Polymer - White
Compatible Mounting Bases	SIGA-SB Standard Base, SIGA-RB Relay Base, SIGA-IB Isolator Base, SIGA-AB4, SIGA-AB4G Audible Bases
LED Operation	On-board Green LED - Flashes when polled On-board Red LED - Flashes when in alarm. Compatible Remote Red LED (model SIGA-LED) Flashes when in alarm
Compatibility	Use With: Signature Loop Controller
Address Requirements	Uses one Device Address
Agency Listing	ActivFire, UL, ULC, CSFM, MEA
UL Listed Spacing	30 ft

Ordering Information

Catalogue Number	Description	Ship Wt. lbs (kg)
SIGA-PHSI	Intelligent 3D Multisensor Detector - ActivFire, UL/ULC Listed	.5 (.23)
Accessories		
SIGA-SB	Detector Mounting Base - Standard	
SIGA-SB4	4-inch Detector Mounting Base c/w SIGA-TS4 Trim Skirt	
SIGA-RB	Detector Mounting Base w/Relay	
SIGA-RB4	4-inch Detector Mounting Base w/Relay, c/w SIGA-TS4 Trim Skirt	0.2 (.09)
SIGA-IB	Detector Mounting Base w/Fault Isolator	
SIGA-IB4	4-inch Detector Mounting Base w/ Fault Isolator, c/w SIGA-TS4 Trim Skirt	
SIGA-LED-AU	Remote Alarm LED with indicator labels	
SIGA-AB4G	Audible (Sounder) Base	.3 (0.15)
SIGA-TS4	Trim Skirt (supplied with 4-inch bases)	.1 (.04)