



LIFE SAFETY & INCIDENT MANAGEMENT

Battery Distribution Unit

3-BTSEN



Approvals

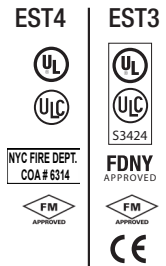

EN 54-2: 1997 + A1: 2006
 EN 54-4: 1997 + A1: 2002 + A2: 2006
 EN 54-16: 2008

Overview

The 3-BTSEN consists of a circuit breaker and copper bus bars mounted on a sheet metal bracket. The unit provides a backup battery bus for supplying backup power to multiple power supplies fed by a common battery. The 3-BTSEN features a 50 Amp circuit breaker to protect the backup battery. The 3-BTSEN mounts in the BC-1 Battery cabinet or any or any 3-RCC series enclosure.

Standard Features

- 50 Amp circuit breaker
- 24 Vdc power distribution bus

Application

The 3-BTSEN is designed to protect and distribute standby 24 Vdc from a large common battery to multiple power supplies in the systems control cabinet.

Engineering Specification

Where a remote battery cabinet is required to house large standby batteries for the fire alarm system cabinet, the remote battery cabinet shall be equipped with a circuit breaker and distribution bus.

Mounting

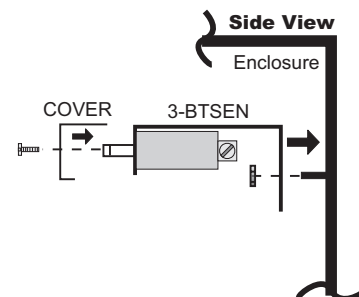



LIFE SAFETY & INCIDENT MANAGEMENT

Contact us

Phone: 800-655-4497 (Option 4)
 Email: edwards.fire@carrier.com
 Website: edwardsfiresafety.com

8985 Town Center Pkwy
 Bradenton, FL 34202

© 2020 Carrier
 All rights reserved.

Typical Wiring

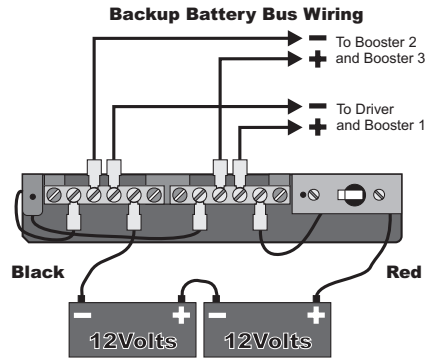

Allowable Wire Distance Per Pair Between Remote Battery Cabinet and Power Supplies				
# of supplies fed by wiring	Wire Size			
	#18 AWG (0.75mm ²)	#16 AWG (1.0mm ²)	#14 AWG (1.5mm ²)	#12 AWG (2.5mm ²)
1	8.84 ft (2.7m)	14 ft (4.27m)	22.4 ft (6.83m)	35.4 ft (10.79m)
2	4.43 ft (1.35m)	7 ft (2.13m)	11.2 ft (3.41)	17.7 ft (5.4M)

Specifications

EST3 Agency Listings	UL, ULC, EN 54-2: 1997 + A1: 2006, EN 54-4: 1997 + A1: 2002 + A2: 2006, and EN 54-16: 2008
EST4 Agency Listings	UL, ULC
Mounting	BC-1 or 3-RCC Series enclosures
Power Rating	50 Amps @ 24 Vdc
Power Bus Connections	#10-32 machine screws
Operating Environment	32°F (0°C) to 120°F (49°C), 93% RH, non-condensing

Ordering Information

Catalog Number	Description	Shipping Wt., lb (kg)
3-BTSEN	Battery Distribution Bus	1 (.45)
3-BTSEN-E*	Remote battery cabinet interlace, temperature sensing	1 (.45)

* EN 54-2: 1997 + A1: 2006, EN 54-4: 1997 + A1: 2002 + A2: 2006, and EN 54-16: 2008. EN54 approval for EST3 applications only.